





MOTOR SPECIFICATION

Frequency	50Hz or 60Hz
Insulation Class	"B","E" standard, "F" Available
Protection Grade	"IP21" standard, "IP54" Available
Heat Protection	Available with Thermostats or Termistors
Electronic Regulation	"ACVV", "VVVF" Available
Pole	4P, 6P, 4/16P, 6/24P
Power	5.5kW(7.3HP)

PERFORMANCE

Efficiency of Power Transfer : 85%
 Shaft Load : 3,700kg
 Noise : 58dB(A)
 Vibration : 7µm
 Brake : Magnetic Brake
 Non Asbestos
 DC 110V, 1.5A
 Weight : 450Kg(with motor)
 Lubricating oil : ISO VG #320, 7 ℓ

6-9 PERSONS ELEVATOR TRACTION MACHINE

(HS150A)

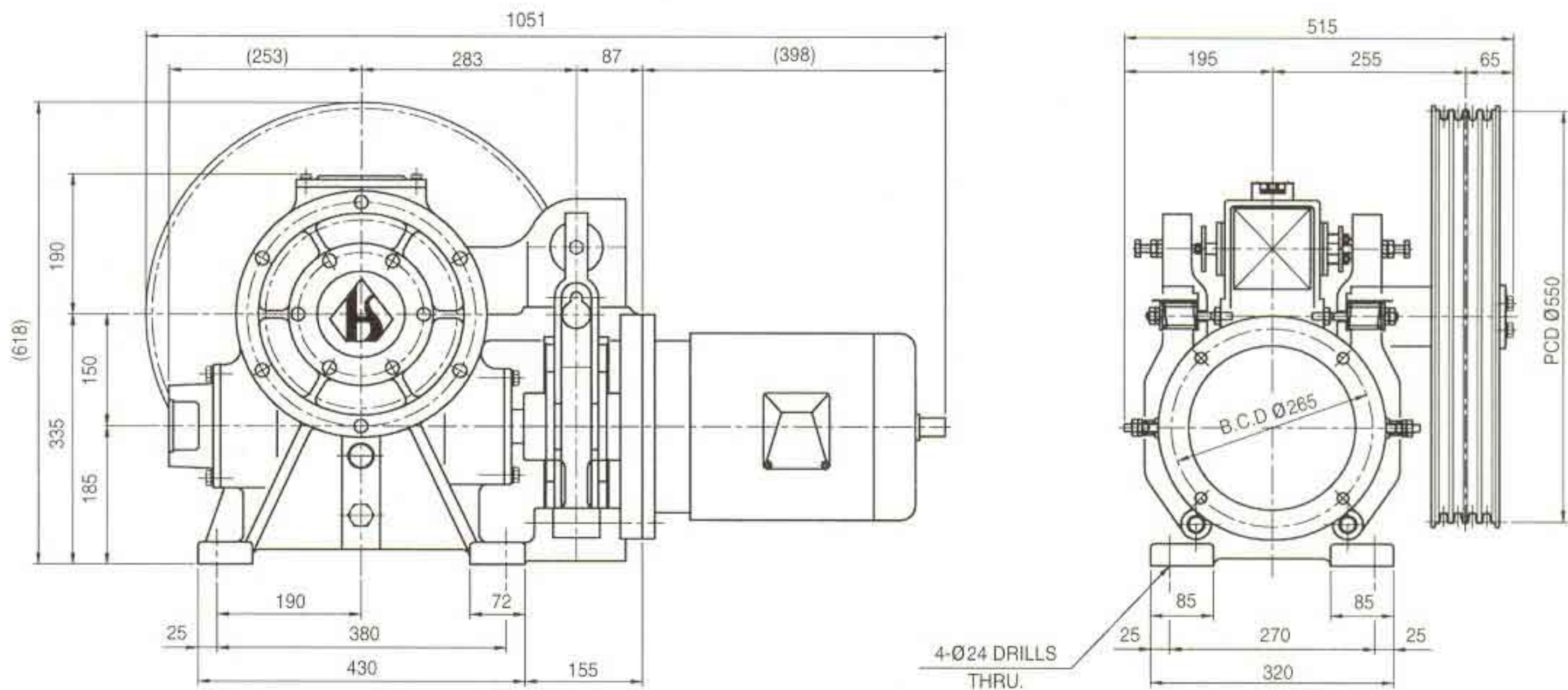

Hz	RATED SPEED	RATIO	SHEAVE DIA.	MOTOR SPEC.	RATED LOAD	ROPE	ROPING
60	30m/min	1 / 58	Ø 480	5.5 kW X 6p	850kg	Ø12 x 3 / 4 (Pitch 19)	1 : 1
	45m/min				800kg		
	60m/min	1 / 49	Ø 550	5.5 kW X 4p	600kg		
	90m/min	2 / 59	Ø 480		400kg		
	105m/min				350kg		
	120m/min	2 / 49	Ø 550		300kg		
50	30m/min	1 / 58	Ø 550	5.5 kW X 6p	850kg	Ø12 x 3 / 4 (Pitch 19)	1 : 1
	45m/min				800kg		
	60m/min	1 / 38	Ø 500	5.5 kW X 4p	600kg		
	90m/min	2 / 49	Ø 480		400kg		
	105m/min	2 / 43	Ø 500		350kg		
	120m/min				300kg		



Certificate of Approval

Awarded to
S. A. SISTEL
SABADELL (BARCELONA)
SPAIN

Bureau Veritas Quality International España, S.A.
certifies that the Quality Management System of the above
organization has been assessed and found to be
in accordance with the requirements
of the quality standards detailed below

QUALITY STANDARDS

UNE EN ISO 9001:2000

SCOPE OF SUPPLY

DESIGN, DEVELOPMENT, PRODUCTION, INSTALLATION AND SERVICING OF
PRODUCTS AND SYSTEMS FOR INDUSTRIAL CONTROL AND REGULATIONS.

Original approval date: 16th OCTOBER 1999

Subject to the continued satisfactory operation of the organization's
Quality Management System, this Certificate is valid until:

From: 14th DECEMBER 2002 Until: 14th DECEMBER 2005

Date: 24th JANUARY 2003



Certificate No: 03.01.240331

